

HOT WATER HEAT PUMP

DATA BOOK

MODEL

CAHV-P500YB-HPB(-BS)

1. Product Specifications

1-2. External Dimensions

CAHV-P500YB-HPB(-BS)

Unit: mm

Note.
Please install the drain pan because defrosting water or dew condensation water drops from holes on the unit base.

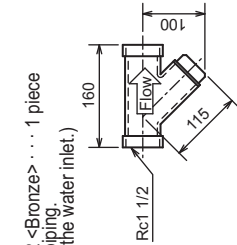

<Accessory>
• Y type strainer 1-1/2 <Bronze> . . . 1 piece
(This is for the water piping.
Please install it near the water inlet.)

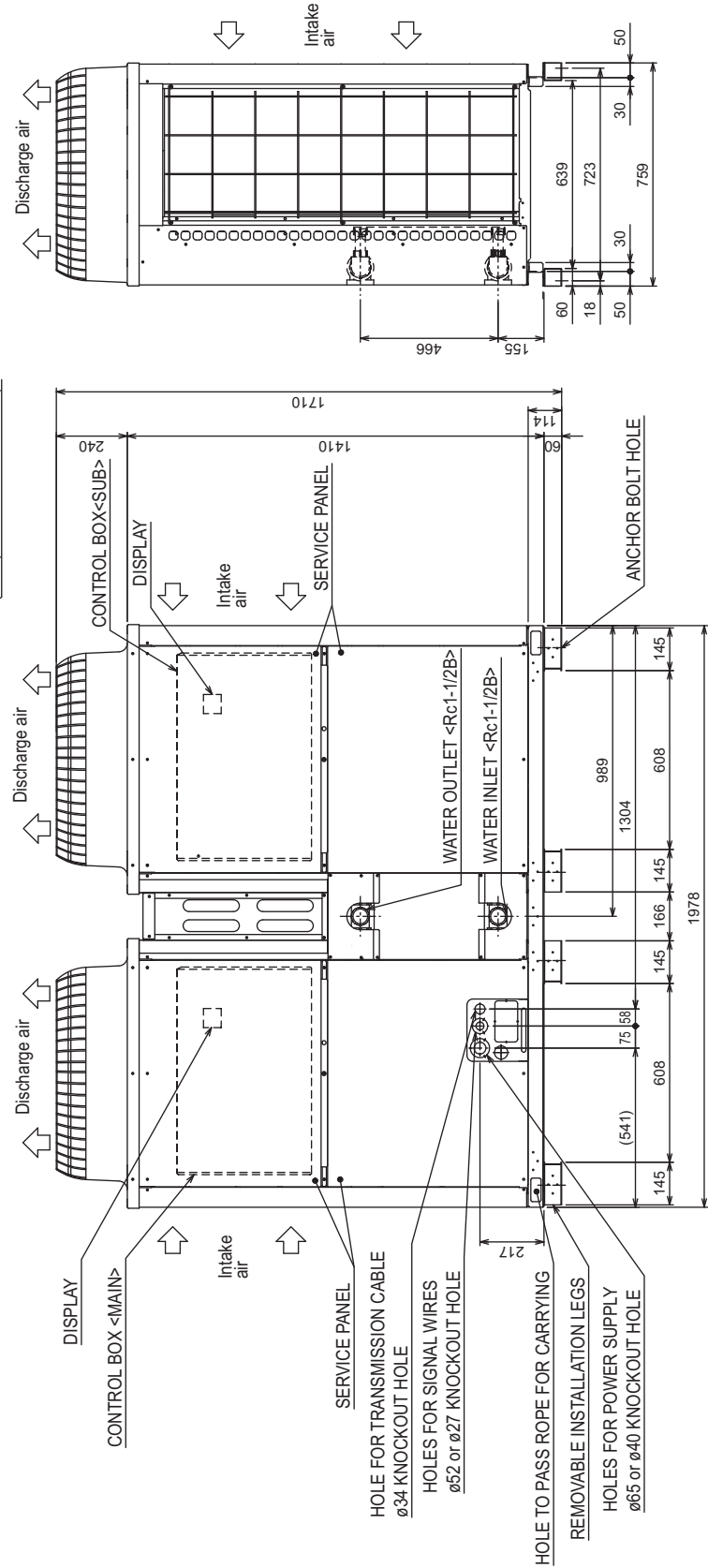
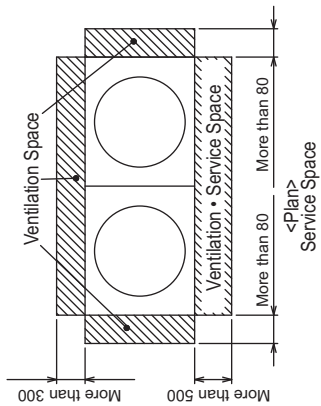
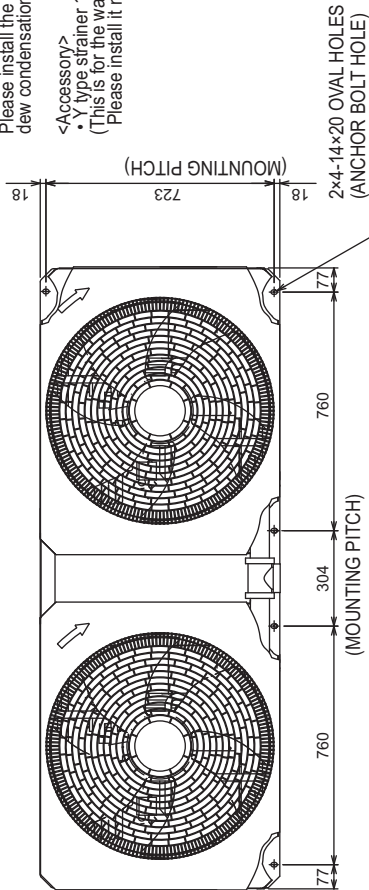

1. Product Specifications

1-3. Center of Gravity

Unit: mm

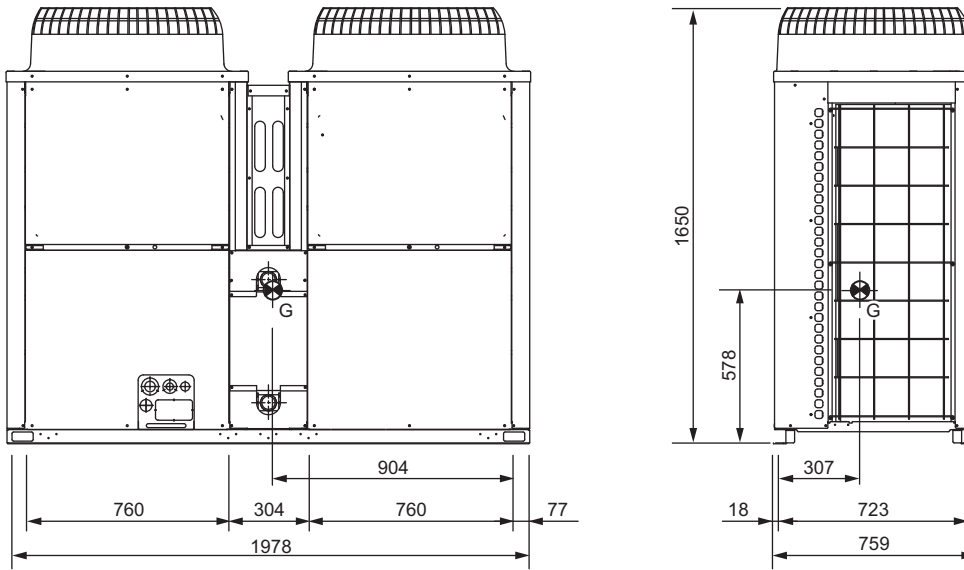

1. Product Specifications

CAHV-P500YB-HPB(-BS)

Symbol explanation	Symbol	explanation
	CH	Crankcase heater (for heating the compressor)
	CT12	Ac current sensor
	CT3	Capacitor (Electrolysis)
	C100	DC reactor
	DCL	
	F01	
	F02	
	F03	Fuse
	F04	
	F05	
	F06	
	LEV1	Electronic expansion valve (Main circuit)
	LEV2	Electronic expansion valve (injection)
	M	Fan motor
MAIN BOX and SUB BOX	MS	Compressor motor
	RT	
	R5	Electrical resistance
	SV1	Solenoid valve (Injection circuit)
	SV2	Solenoid valve (Hot gas circuit)
	THHS	IGBT temperature
	Z21	Function setting connector
	Z1S4	4-way valve
	63HS	High pressure sensor
	63H1	High pressure switch
	63LS	Low pressure sensor
	72C	Electromagnetic relay (Inverter main circuit)
MAIN BOX	TH1~4	Thermistor
	TH9,11	
	TH14~16	
SUB BOX	TH5~8	Thermistor
	TH12,13	
Field-supplied	<ELB1,2,3>	Earth leakage breaker
	<F2,3>	Fuse
	<MP>	Pump motor
	<51P>	Overcurrent relay (Pump)
	<52P>	Electromagnetic contactor (Pump)

Note

- The broken lines indicate the optional parts, field-supplied parts, and field work.
- Make sure to connect a pump interlock contact.
A short-circuit may cause abnormal stop or malfunctions.
- The preset temperature setting can be switched from the no-voltage contact or by setting time ranges.
- Leave a space of at least 5 cm between the low voltage external wiring (no-voltage contact input and remote controller wiring) and wiring of 100V or greater. Do not place them in the same conduit tube or cable tray as this will damage the circuit board.
- When cable tray is used for the control cable wiring, use a separate cable tray for the following wiring.
Using the same cable tray may cause malfunctions and damage to the unit.
 - Optional remote controller wiring
 - No-voltage contact input wiring
 - No-voltage contact output wiring
 - Remote water temperature setting
- Use a contact that takes 12VDC 5mA for no-voltage contact input.

1. Product Specifications

1-5. Accessories

CAHV-P500YB-HPB(-BS)

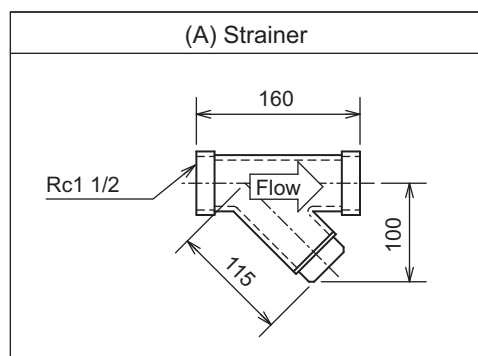

(A) Install the strainer at the water pipe inlet.

1-6. Optional parts

1-6-1. IT TERMINAL BOX

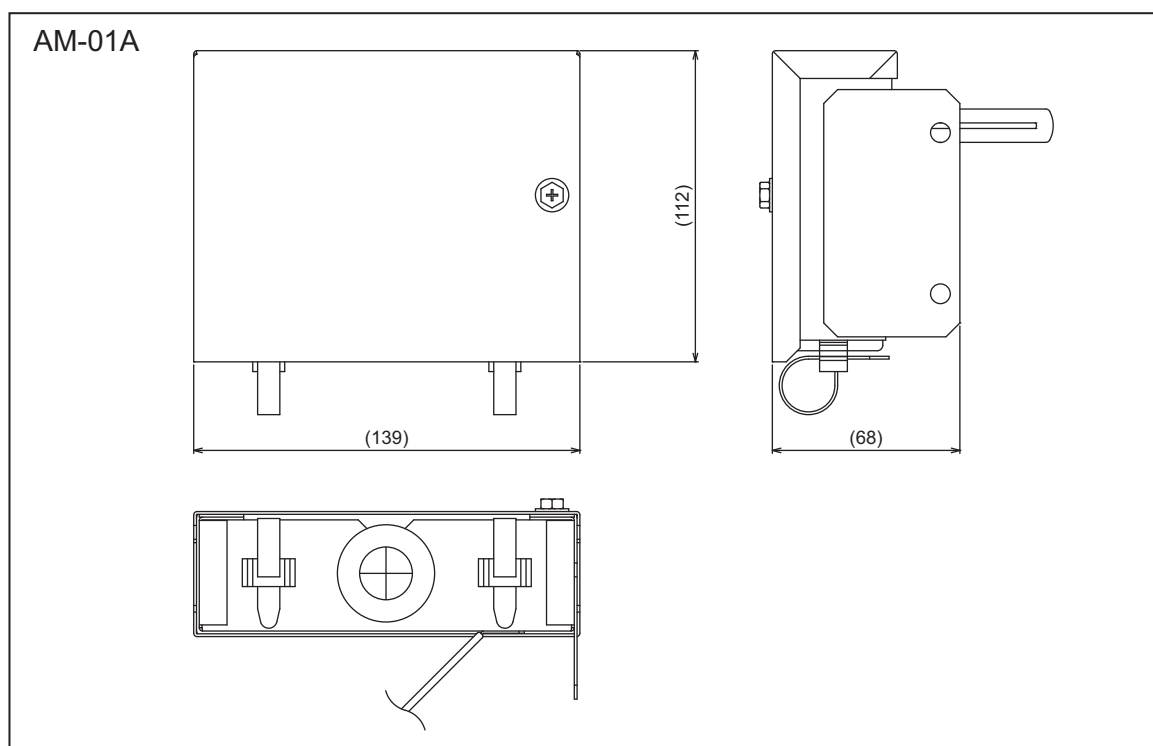

*For the installation, refer to the Installation Manual that comes with the IT TERMINAL BOX.

1. Product Specifications

1-6-2. Representative-water temperature sensor TW-TH16

1. Required parts for installing a representative-water temperature sensor
 - A) Representative-water temperature sensor
 - B) Cable for connecting between the sensor and the unit*
 - C) Cable terminal for connecting to the sensor and the unit terminal block*
(Terminals for M4 screws × 4)*

* A) and B) are field-supplied.

Cable specifications

Size	2-core, 1.25 mm ² or larger
Type	CVVS or CPEVS
Length	20 m

2. Installing a representative-water temperature sensor

As shown in the figures below, install the sensor at the merged part of water pipes or the load-side tank.

The sensor can be installed in either the vertical or the horizontal position. When installing the sensor in the horizontal position, make sure to place the cable-access-hole side down.

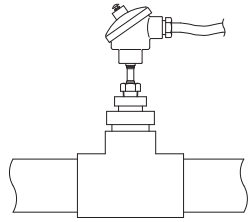

Vertical installation

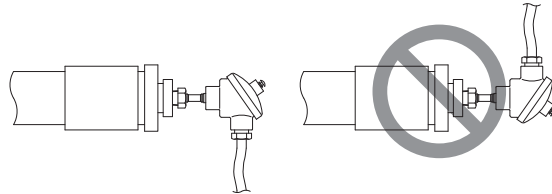

Horizontal installation

3. Wiring for a representative-water temperature sensor

As shown in the figures below, connect the cable to the representative-water temperature sensor and the terminal block in the unit control box.

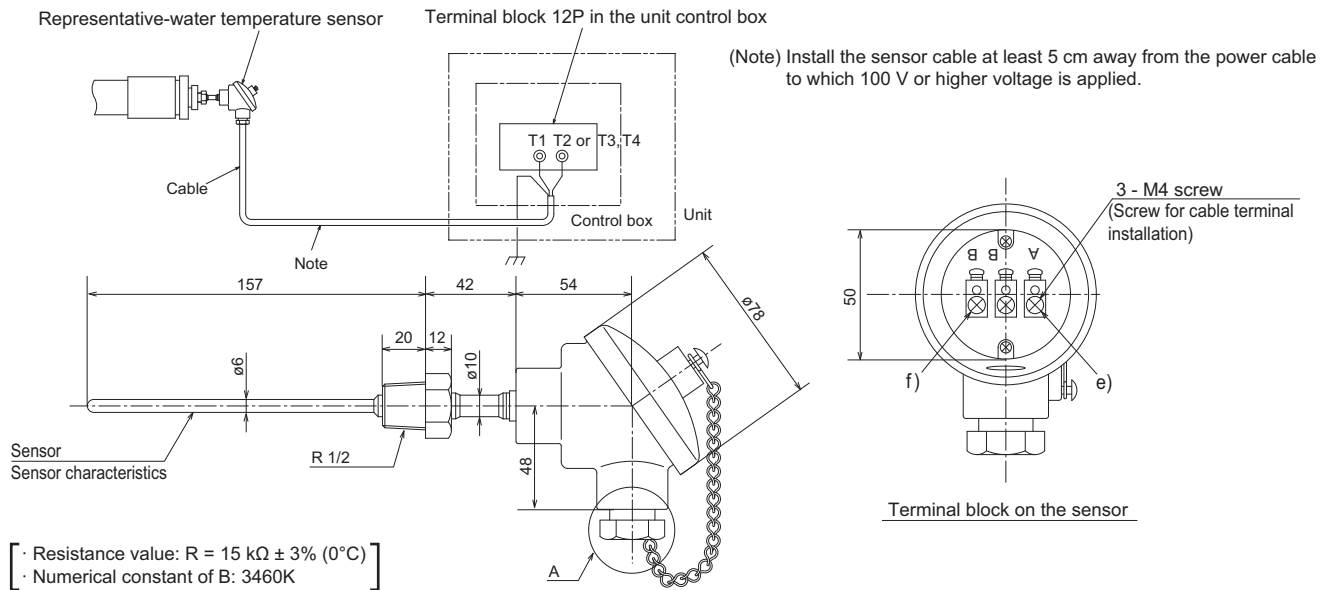

On the unit side, connect the sensor cable to the terminals T1 and T2 in the terminal block 12P in the unit control box.

Connect the shielded cable to the ground terminal.

On the sensor side, as shown in the figure at right, run the cable through d), c), and b), attach the field-supplied terminals for M4 screws to the cable, and then connect the terminals to the screws e) and f) (terminal A and B).

Cut the shielded cable and leave it unconnected.

(On the unit side, the shielded cable should be connected to the ground terminal already.)

Tighten the tightening screw d), and caulk the gap between the tightening screw d) and cable a) to prevent water leakage.

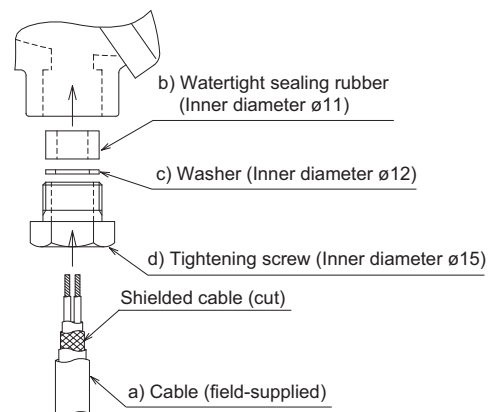

Enlarged view of area A: Cable installation

2. Product Data

2-1. Capacity tables

2-1-1. Correction by temperature

CAHV-P500YB-HPB(-BS)

(1) Efficiency Priority Mode

Capacity		Intake air temperature °C															
		-20	-15	-10	-7	-5	0	2	5	7	10	16	20	25	30	35	40
Outlet water temperature °C	35	-	-	40.3	42.2	42.4	42.7	42.8	43.5	45.0	45.0	45.0	45.0	45.0	45.0	45.0	45.0
	45	32.0	37.4	40.6	42.4	42.6	42.9	43.0	43.5	45.0	45.0	45.0	45.0	45.0	45.0	45.0	45.0
	55	32.2	37.7	40.8	42.7	42.8	43.1	43.2	43.6	45.0	45.0	45.0	45.0	45.0	45.0	45.0	45.0
	60	32.2	37.8	40.9	42.8	42.9	43.2	43.3	43.7	45.0	45.0	45.0	45.0	45.0	45.0	45.0	45.0
	65	32.2	37.9	41.0	42.9	43.0	43.3	43.4	43.7	45.0	45.0	45.0	45.0	45.0	45.0	45.0	45.0
	70	-	-	41.1	43.0	43.1	43.4	43.5	43.7	45.0	45.0	45.0	45.0	45.0	45.0	45.0	45.0

This table shows the capacity when the relative humidity is 85%.

The intake wet-bulb temperature is fixed to 32°C when the intake dry-bulb temperature is 35°C or higher.

Power input		Intake air temperature °C															
		-20	-15	-10	-7	-5	0	2	5	7	10	16	20	25	30	35	40
Outlet water temperature °C	35	-	-	17.0	16.9	16.2	14.7	14.2	12.0	10.9	9.82	8.20	7.40	6.60	6.30	6.02	5.77
	45	18.4	19.4	19.4	19.5	18.7	17.0	16.4	14.2	12.9	11.9	10.1	9.08	8.05	7.73	7.44	7.17
	55	21.2	22.5	22.7	22.8	22.0	20.1	19.5	17.5	16.5	15.2	13.2	12.1	11.0	10.3	9.75	9.24
	60	22.9	24.5	24.8	25.0	24.1	22.1	21.4	19.1	17.8	16.6	14.7	13.6	12.4	11.6	10.8	10.2
	65	24.9	26.8	27.3	27.6	26.7	24.6	23.9	22.2	21.3	19.6	16.9	15.4	14.0	13.0	12.1	11.4
	70	-	-	30.2	30.8	29.8	27.6	26.9	25.7	25.6	23.9	19.9	18.0	16.0	14.8	13.8	12.9

This table shows the power input when the relative humidity is 85%.

The intake wet-bulb temperature is fixed to 32°C when the intake dry-bulb temperature is 35°C or higher.

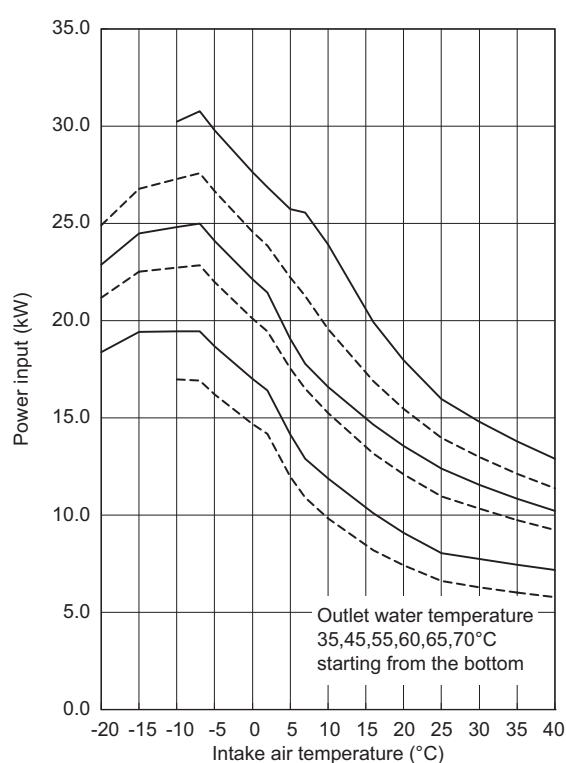
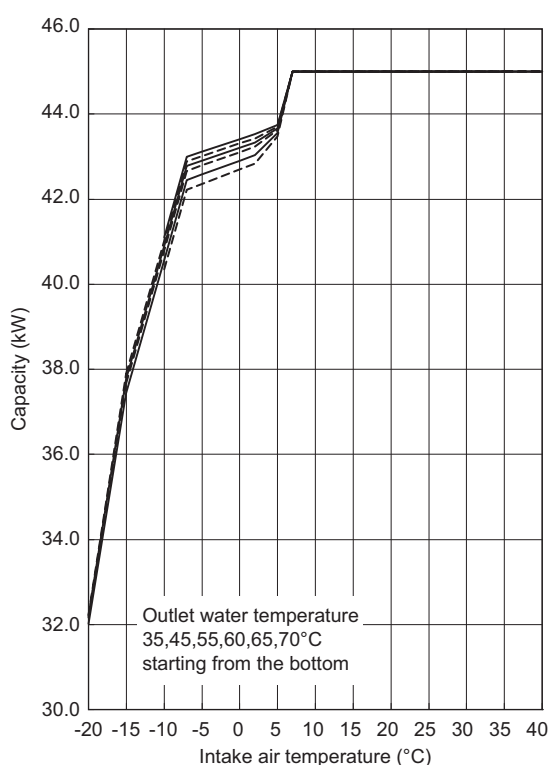

2. Product Data

(2) Capacity Priority Mode

Capacity		Intake air temperature °C															
		-20	-15	-10	-7	-5	0	2	5	7	10	16	20	25	30	35	40
Outlet water temperature °C	35	-	-	40.3	42.2	42.4	42.7	45.4	49.6	63.4	65.9	71.3	73.9	75.4	73.0	70.5	68.0
	45	32.0	37.4	40.6	42.4	42.6	42.9	45.0	49.1	63.2	65.6	70.4	73.0	74.8	72.2	69.6	67.0
	55	32.2	37.7	40.8	42.7	42.8	43.1	44.5	48.8	62.8	65.9	69.6	71.3	71.0	69.2	67.5	65.7
	60	32.2	37.8	40.9	42.8	42.9	43.2	44.1	48.6	61.5	64.8	68.6	69.7	69.4	68.1	66.8	65.5
	65	32.2	37.9	41.0	42.9	43.0	43.3	43.7	48.5	60.1	63.1	67.6	68.7	67.8	66.9	66.1	65.2
	70	-	-	41.1	43.0	43.1	43.4	43.5	48.3	58.7	61.3	65.8	66.7	66.1	65.7	65.4	65.0

This table shows the capacity when the relative humidity is 85%.

The intake wet-bulb temperature is fixed to 32°C when the intake dry-bulb temperature is 35°C or higher.

Power input		Intake air temperature °C															
		-20	-15	-10	-7	-5	0	2	5	7	10	16	20	25	30	35	40
Outlet water temperature °C	35	-	-	17.0	16.9	16.2	14.7	15.6	15.2	17.7	17.0	16.2	15.3	13.9	12.7	11.6	10.8
	45	18.4	19.4	19.4	19.5	18.7	17.0	17.8	17.6	20.9	20.2	19.2	18.1	16.6	14.6	12.9	11.8
	55	21.2	22.5	22.7	22.8	22.0	20.1	20.8	21.2	25.6	25.3	23.9	22.2	19.5	17.4	15.6	14.1
	60	22.9	24.5	24.8	25.0	24.1	22.1	22.6	23.4	27.9	27.9	26.6	24.3	21.3	19.0	17.2	15.6
	65	24.9	26.8	27.3	27.6	26.7	24.6	24.8	25.8	30.1	30.2	29.6	27.0	23.2	20.9	19.0	17.4
	70	-	-	30.2	30.8	29.8	27.6	27.5	28.6	32.6	32.7	32.5	29.5	25.2	23.1	21.3	19.7

This table shows the power input when the relative humidity is 85%.

The intake wet-bulb temperature is fixed to 32°C when the intake dry-bulb temperature is 35°C or higher.

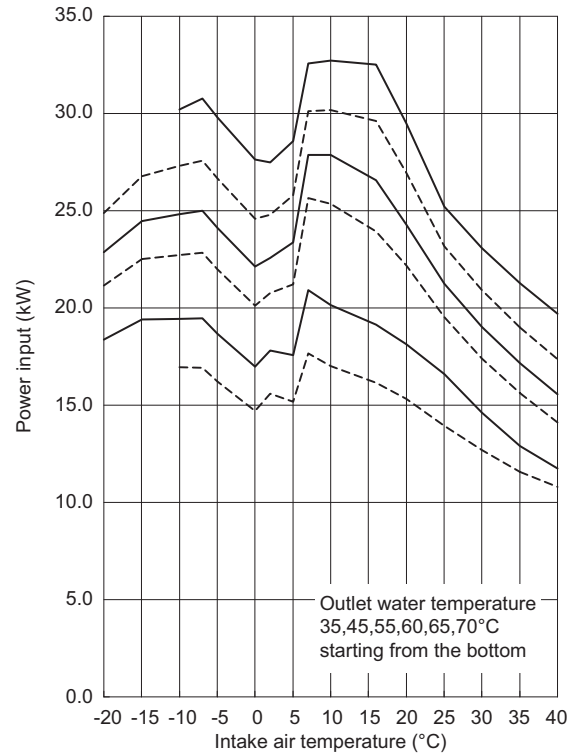
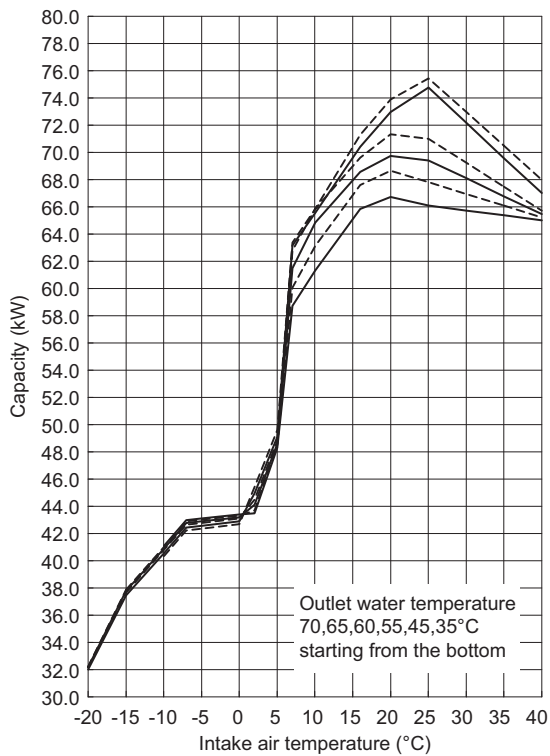

2. Product Data

2-1-3. Correction by water flow rate

CAHV-P500YB-HPB(-BS)

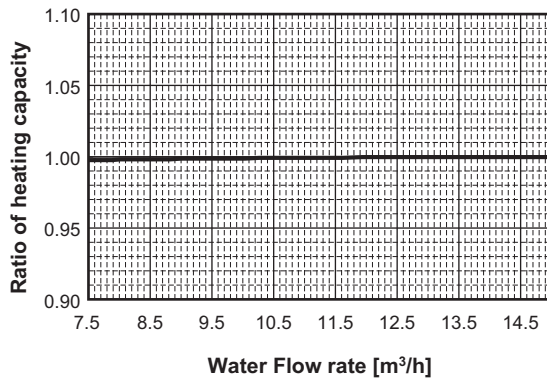

*Conditions Outdoor temperature 0°C
Intake water temperature 65°C
Frequency of compressor 100Hz

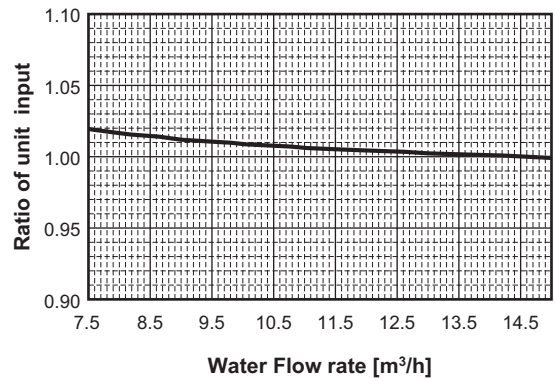

*Conditions Outdoor temperature 0°C
Intake water temperature 50°C
Frequency of compressor 100Hz

2-1-4. Water pressure drop

CAHV-P500YB-HPB(-BS)

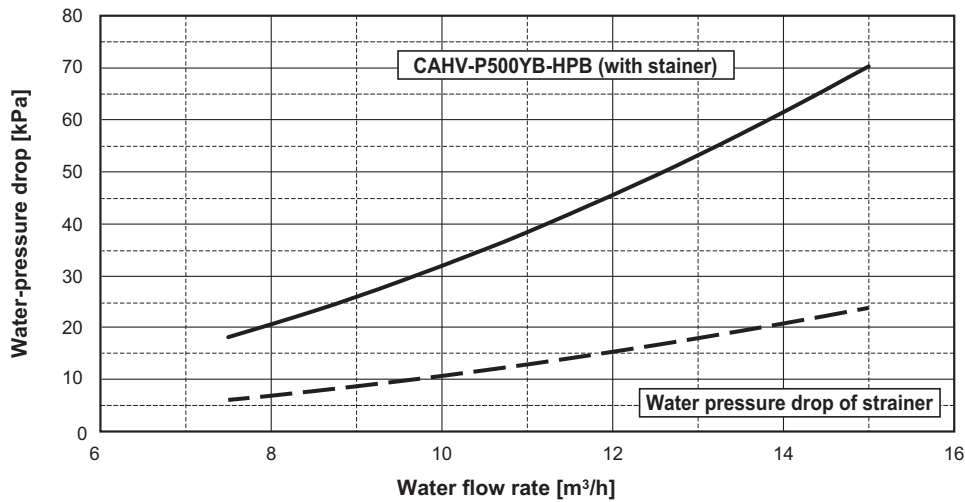

2-1-5. Operation temperature range

CAHV-P500YB-HPB(-BS)

Heating

